



RFL Electronics Inc.

INSTRUCTION DATA

RFL T1/E1 Fiber Service Unit

107600-200

107600-300

107600-400

107600-500

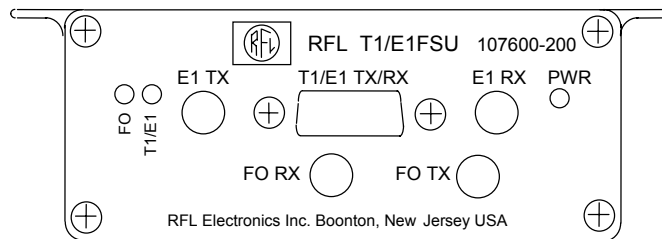

Figure 1. Typical RFL T1/E1Fiber Service Unit, Front Panel view

DESCRIPTION

The RFL T1/E1 Fiber Service Unit (FSU) is an AC/DC powered, environmentally hardened T1/E1 Fiber Service Unit. This device can be electrically interfaced to a SONET or SHD multiplexer and can extend the communication signal over fiber to a T1 or E1 IMUX 2000 multiplexer. When connecting two FSUs end to end, an interface can be provided between any T1 or E1 multiplexer with compliant T1 or E1 electrical interfaces. The characteristics of each of the four types of Fiber Service Units, is shown in Table 1. Mounting dimensions are shown in Figure 7.

Table 1. T1/E1 Fiber Service Unit Characteristics

Assembly Number	Type	Wavelength/Mode/	System Gain	Typical Distance
107600-200	LED Emitter/Detector	1300nm/SM	19 db	26.6 km/16.5 miles
107600-300	LED Emitter/Detector	1300nm/MM	25 db	19.5 km/12.1 miles
107600-400	LASER Emitter/Detector	1300nm/SM	36 db	58.9 km/36.6 miles
107600-500	LASER Emitter/Detector	1500nm/SM	30 db	90 km/55.9 miles

WARNING

YOUR T1/E1 FIBER SERVICE UNIT IS EQUIPPED WITH FIBER INPUT/OUTPUT MODULES THAT HAVE FIBER OPTIC EMITTER HEADS. FIBER OPTIC EMITTER HEADS USE A LASER LIGHT SOURCE THAT PRODUCE INVISIBLE RADIATION. FIBER OPTIC COMMUNICATION SYSTEMS ARE INHERENTLY SAFE IN NORMAL OPERATION BECAUSE ALL RADIATION IS CONTAINED IN THE SYSTEM. IT IS POSSIBLE DURING MAINTENANCE TO EXPOSE THE RADIATION BY REMOVING OR BREAKING THE FIBER. STARING DIRECTLY INTO THE LIGHT BEAM MAY RESULT IN PERMANENT EYE DAMAGE AND/OR BLINDNESS. NEVER LOOK DIRECTLY INTO THE LIGHT BEAM AND BE CAREFUL NOT TO SHINE THE LIGHT AGAINST ANY REFLECTIVE SURFACE.

THE LASER SOURCE IS A CLASS I LASER PRODUCT WHICH COMPLIES WITH APPLICABLE FDA, OSHA AND ANSI STANDARDS.

SPECIFICATIONS

As of the date this Instruction Data Sheet was published, the following specifications apply to the RFL T1/E1 Fiber Service Unit. Because all RFL products undergo constant refinement and improvement, these specifications are subject to change without notice.

Fiber Optic Cable Type: 50 μ m or 62.5 μ m core diameter optical fiber.

Fiber Optic Cable Length: 90 km max (depending on assembly number)

Fiber Optic Connector: Type ST

Wavelength: 1300nm or 1500nm

Mode: singlemode or multimode

Signal Connector Type:

15-pin male type D subminiature for T1 or E1, or dual BNCs for E1

Data Rate:

T1: 1.544 Mb/sec

E1: 2.048 Mb/sec

Input Power Connector:

6-position Terminal Block

RFL Part # 101458-6

Amphenol PCD ELFF06240

Input Power Requirements:

38 to 150 Vdc or 96 to 132 VAC @ 6W

Operating Temperature:

-20^oC to +60^oC (-22^oF to +140^oF)

Relative Humidity: 95 percent @ 40^oC, non-condensing.

Dimensions:

Width: 5.13 inches (13 cm)

Height: 1.77 inches (4.5 cm)

Depth: 11.14 inches (28.3 cm)

Mounting Dimensions: In accordance with Figure 10.

INSTALLATION

Installation involves mounting the FSU module in its desired location, connecting all signal, coaxial and power cables, and programming the module configuration settings, using jumpers and switch settings as required.

To install the module, proceed as follows:

1. Carefully inspect the module for any signs of shipping damage. If you suspect damage to the module, immediately call RFL Customer Service at the number given at the bottom of this page.
2. Check the assembly number on the front panel of the module to make sure the unit is compatible with your interface requirement as shown in Table 1.
3. Use Table 6 as a wiring guide for the D subminiature connector if your interface is 120 ohm E1. Use Table 7 as a wiring guide for the BNC connectors if your interface is 75 ohm T1 or E1. When fastening the D subminiature connector, make sure that the screws on both ends of the mating connector are tightened to secure the connector to the FSU front panel.

NOTE

ALL CABLING TO AND FROM THE FIBER SERVICE UNIT INTERFACE CONNECTOR MUST UTILIZE SHIELDED TWISTED PAIR OR COAXIAL CABLE TO MINIMIZE CROSSTALK AND INTERFERENCE FROM EXTERNAL SOURCES.

CAUTION

BEFORE ATTEMPTING TO MAKE POWER CONNECTIONS TO THE FIBER SERVICE UNIT, MAKE SURE THAT YOUR POWER SOURCE IS COMPATIBLE WITH THE FSU. IF THE IMPROPER VOLTAGE IS CONNECTED TO THE FSU, COMPONENT DAMAGE MAY RESULT.

4. Fiber optic cables with type ST series bayonet fiber optic connectors must be connected to the fiber optic heads on the front panel of the FSU module and to the far end chassis. When connecting fiber optic cables, make sure the connectors are properly aligned before tightening, and then fully tighten them. This will help minimize losses in the connector.
5. Set switches SW1-1 and SW1-2 to select the Loopback mode in accordance with Table 3.
6. Set switches SW1-3 and SW1-4 to select the Receive Termination in accordance with Table 3.
7. Set switch SW1-5 to select the Receive Sensitivity in accordance with Table 3. Note that the settings are different for T1 and E1 systems.

8. Set switches SW1-6, SW1-7 and SW1-8 to select the Line Buildout in accordance with Table 3. Note that the settings are different for T1 and E1 systems. Also note that settings are required for Jumpers J6 and J7.
9. Set switches SW1-9 and SW1-10 to select the Transmit Data Source in accordance with Table 3.
10. Set switch SW2-1 to select the Electrical Phase Locked Loop for T1 or E1 in accordance with Table 4.
11. Set switch SW2-2 to select the Fiber Optic Phase Locked Loop for T1 or E1 in accordance with Table 4.
12. Set switch SW2-3 to select the Transceiver for T1 or E1 in accordance with Table 4.
13. Set switch SW2-4 to enable or disable HDB3/B8ZS in accordance with Table 4.
14. Set switch SW2-5 to enable or disable the Internal Timing in accordance with Table 4.
15. Set switch SW2-6 to enable or disable the Jitter Attenuator in accordance with Table 4.
16. Set switch SW2-7 to select whether the Jitter Attenuator is in the Tx path or Rx path.
17. Remove the Terminal Block connector from the FSU rear panel. Connect input power to the following terminals on the terminal block connector as follows:

Station battery positive	TB1-1
Station battery negative	TB1-2
Ground	Ground Stud on rear panel
18. Connect to Alarm Contacts as follows:

TB1-4	NC
TB1-5	NO
TB1-6	COM
19. Plug the Terminal Block into the FSU rear panel TB1 connector. The FSU is now installed and powered up. The FSU has no power ON/OFF switch. It is powered up as soon as power is connected. For more information consult the Instruction Manual for the RFL IMUX 2000 or the other T1/E1 compliant device as applicable.

WARNING

**INSURE THAT ALL FIBER OPTIC CABLES ARE CONNECTED BEFORE
POWERING-UP THE FSU**

CONTROLS AND INDICATORS

The RFL TX/RX FSU has user controls and indicators as shown in Figure 2. The figure shows the location of all controls, indicators and connectors on the front, rear and side panels of the FSU module. Figures 3 and 4 show the location of controls and indicators on Board A and Board B. The function of all controls and indicators are described in Tables 2 through 5, and Table 8.

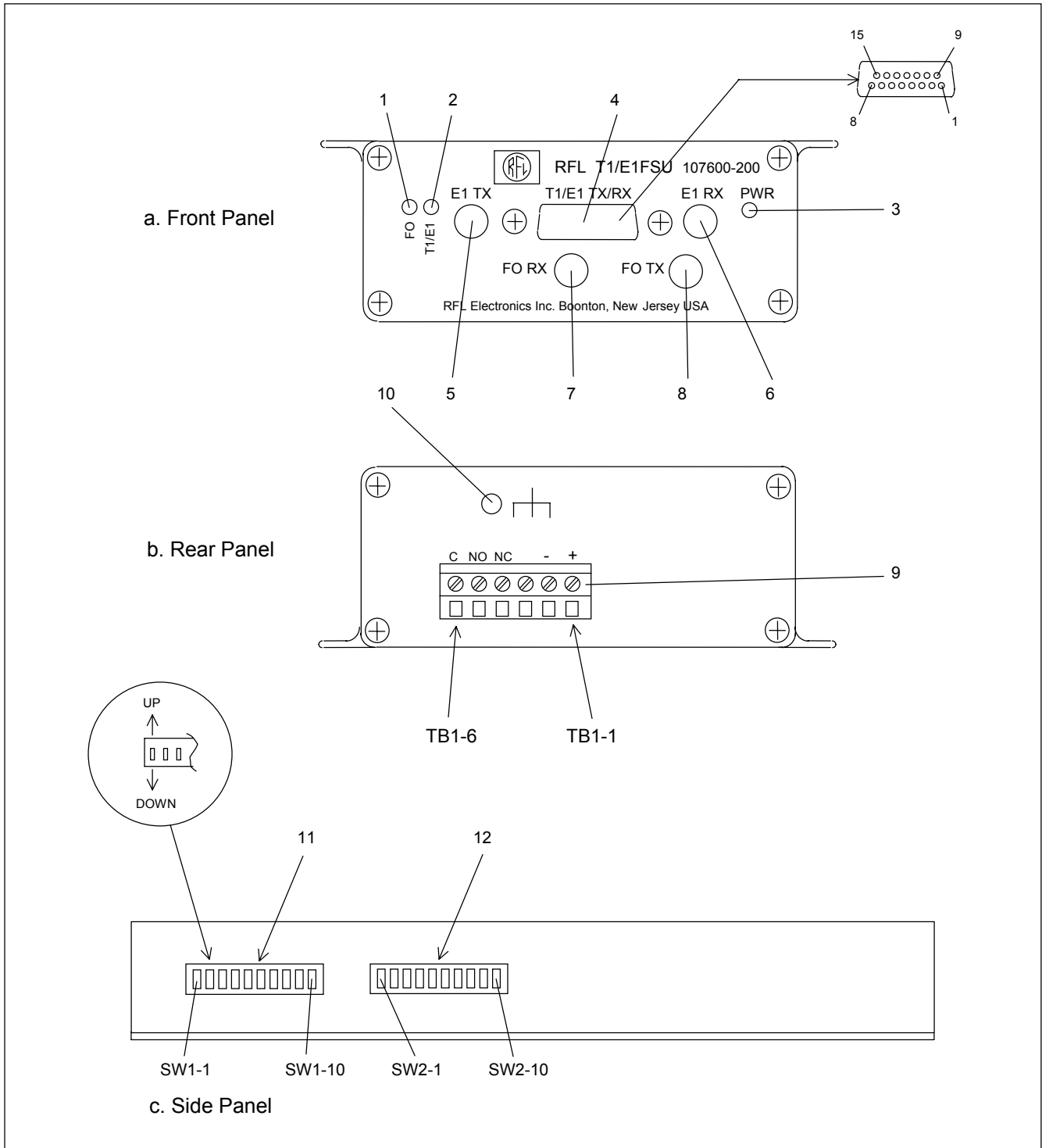

Figure 2. Fiber Service Unit, front, rear, and side panel controls and indicators

Table 2. T1/E1 FSU Controls and Indicators

Item Number	Reference Designation	Description	Function
1	DS1	FO LED	Fiber Optic status indicator. Lights “green” when fiber optic data is being received.
2	DS2	T1/E1 LED	T1/E1 status indicator. Lights “green” when electrical data is being received..
3	DS3	Power LED	Power status indicator. Lights “green” when power is applied to the input power terminals.
4	J5	T1/E1 Tx/Rx Port	120 Ohm, DB-15 male T1/E1 Tx/Rx connector
5	J1	E1 Tx Port	75 Ohm E1 Tx connector (BNC)
6	J2	E1 Rx Port	75 Ohm E1 Rx connector (BNC)
7	CR1	Fiber Optic Detector	Fiber optic detector with type ST connector
8	CR2	Fiber Optic Emitter	Fiber optic emitter with type ST connector
9	TB1	Terminal Block	Provides input power and alarm relay output connections
10	---	Ground Stud	Earth ground connection
11	SW1	10-pole DIP switch	Used to set operating parameters in accordance with Table 3
12	SW2	10-pole DIP switch	Used to set operating parameters in accordance with Table 4

ALARM RELAY

The normally open (NO) contacts will close and the normally closed (NC) contacts will open if the T1/E1 FSU goes into an alarm condition. An alarm condition occurs if the FSU fails to receive electrical data, fails to receive optical data, or if power is disconnected from the FSU.

ENCODING PRECAUTIONS

The T1/E1 FSU *optical* interface supports CMI encoding only. The T1/E1 FSU *optical* interface does not support HDB3 or B8ZS encoding. SW2-4 selects the encoding of the *electrical* interface only.

To be compatible with the T1/E1 FSU, a CM3 or CM3R using an OIA must be set to AMI, and the OIA must be set to CMI. For this reason, when interfacing a T1/E1 FSU to a CM3 or CM3R via an OIA, the CM3/CM3R will lose sync if it receives greater than 22 consecutive timeslots of all zeros.

When interfacing the T1/E1 Fiber Service Unit (RFL part numbers 107600-200 thru 107600-500) to the Fiber Optic port on the 8-Port DACS, the Line Coding of the 8-Port DACS must be set to AMI.

Table 3. SW1 Switch Positions

Switch	Function					
SW1	SW1-1 and SW1-2 Loopback Select					
	<u>SW1-1</u>	<u>SW1-2</u>	<u>Mode</u>			
	Down	Down	No Loopback (factory setting)			
	Up	Up	T1/E1 Loopback (data entering the electrical interface is looped back)			
	Up	Down	Fiber Optic Loopback (data entering the fiber optic interface is looped back)			
	SW1-3 and SW1-4 Receive Termination					
	<u>SW1-3</u>	<u>SW1-4</u>	<u>Termination</u>			
	Up	Up	75 Ohms			
	Down	Up	100 Ohms			
	Up	Down	120 Ohms			
	SW1-5 T1/E1 Receive Sensitivity					
	<u>SW1-5</u>	<u>T1 Receive Sensitivity</u>				
	Up	-30 dB (limited long haul)				
	Down	-36 dB (long haul)				
	<u>SW1-5</u>	<u>E1 Receive Sensitivity</u>				
	Up	-43 dB (long haul)				
	Down	-12 dB (short haul)				
	SW1-6, SW1-7 and SW1-8 T1 Line Buildout Select					
	<u>SW1-6</u>	<u>SW1-7</u>	<u>SW1-8</u>	<u>Jumper J6*</u>	<u>Jumper J7*</u>	<u>T1 Line Buildout</u>
	Down	Down	Down	A	A	0-133 feet
Up	Down	Down	A	A	133-266 feet	
Down	Up	Down	A	A	266-399 feet	
Up	Up	Down	A	A	399-533 feet	
Down	Down	Up	A	A	533-655 feet	
Up	Down	Up	A	A	-7.5 dB	
Down	Up	Up	A	A	-15 dB	
Up	Up	Up	A	A	-22.5 dB	
SW1-6, SW1-7 and SW1-8 E1 Line Buildout Select						
<u>SW1-6</u>	<u>SW1-7</u>	<u>SW1-8</u>	<u>Jumper J6*</u>	<u>Jumper J7*</u>	<u>E1 Line Buildout</u>	
Down	Down	Down	A	A	75 Ohm normal	
Up	Down	Down	A	A	120 Ohm normal	
Down	Down	Up	B	B	75 Ohm w/high return loss	
Up	Down	Up	C	C	120 Ohm w/high return loss	
SW1-9 and SW1-10 Transmit Data Source						
<u>SW1-9</u>	<u>SW1-10</u>	<u>Transmit Data</u>				
Down	Down	Received Fiber Data (factory setting)				
Up	Up	All Ones Pattern				
Down	Up	Alternating Ones and Zeroes				

*See Figure 3 for jumper locations

Table 4. SW2 Switch Positions

Switch	Function
SW2	SW2-1 Electrical T1/E1 PLL Select <u>SW2-1</u> <u>Mode*</u> Up T1 Down E1
	SW2-2 Fiber Optic T1/E1 PLL Select <u>SW2-2</u> <u>Mode*</u> Up T1 Down E1
	SW2-3 Transceiver T1/E1 Select <u>SW2-3</u> <u>Mode*</u> Up T1 Down E1
	SW2-4 AMI or B8ZS/HDB3 Select (electrical interface only) <u>SW2-4</u> Up AMI Down B8ZS/HDB3
	SW2-5 Internal Timing Enable <u>SW2-5</u> Up disable Down enable
	SW2-6 Jitter Attenuator Enable (electrical interface only) <u>SW2-6</u> Up disable Down enable
	SW2-7 Jitter Attenuator Select <u>SW2-7</u> Up Tx Path Down Rx Path
	SW2-8 Not Used
	SW2-9 Not Used
	SW2-10 Not Used

* Switches SW2-1, SW2-2 and SW2-3 must all be in either the T1 position or the E1 position.

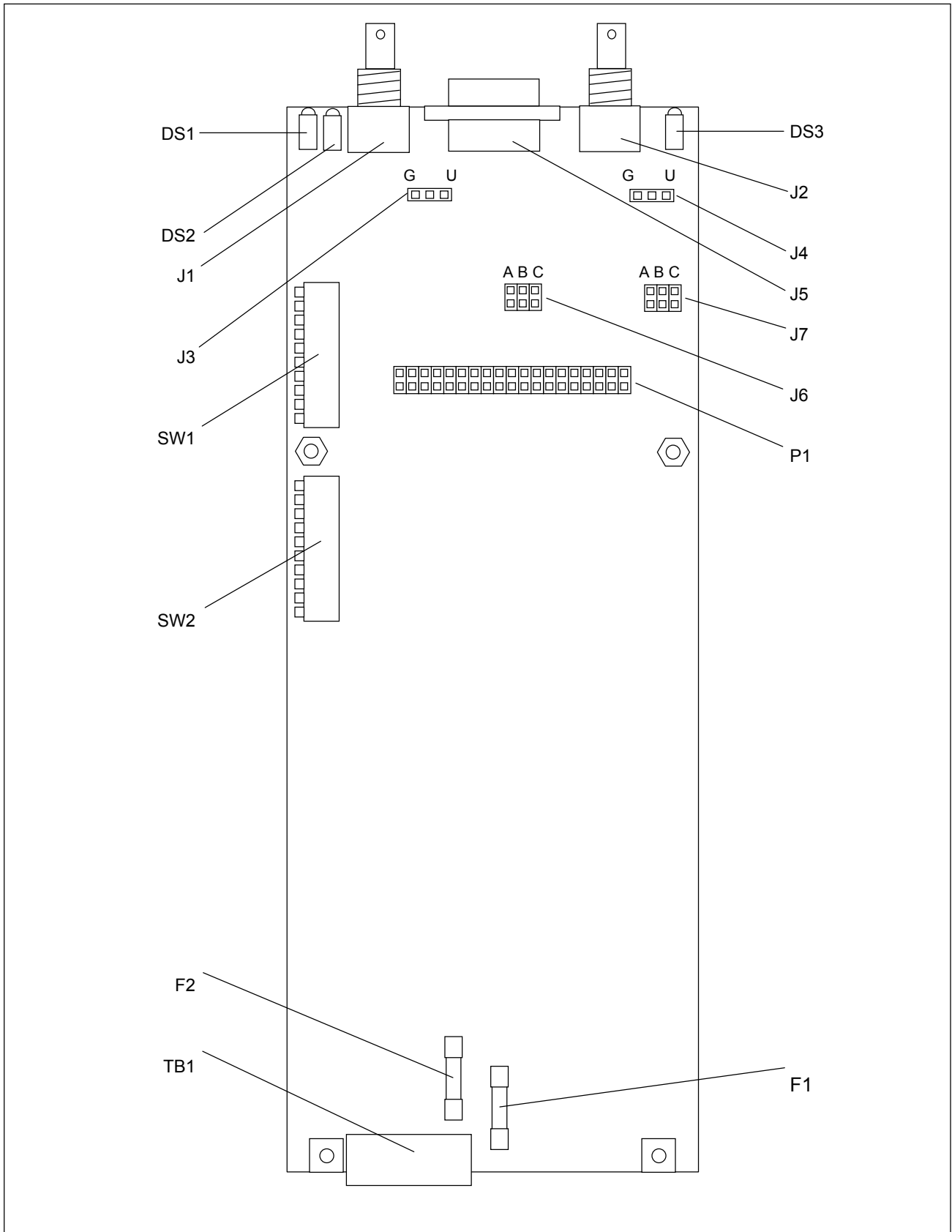

Figure 3. Controls and indicators, T1/E1 Fiber Converter board (Board A)

Table 5. Controls and indicators, T1/E1 Fiber Converter board (Board A)

Reference Designation	Function
DS1	Fiber Optic status indicator
DS2	T1/E1 Status indicator
DS3	Power Status indicator
SW1	10-pole DIP switch for setting up module parameters
SW2	10-pole DIP switch for setting up module parameters
J1	Fiber Optic emitter
J2	Fiber Optic detector
J3, J4	Programmable jumpers used to ground the outer conductor of the BNC connectors when necessary. Both jumpers should be set to "U" when using the DB-15 T1/E1 port.
J5	DB15 subminiature connector
J6	Programmable jumper (See Table 3 for jumper functions)
J7	Programmable jumper (See Table 3 for jumper functions)
P1	Connects signals from board A to board B
F1	Fuse (1)
F2	Fuse (1)
TB1	Input power and alarm relay terminal board (See Page 6 for pinouts)

Note 1: RFL part number 104545, 0.25A, 250V, slo-blow, 5x20mm.

Table 6. T1/E1 120 Ohm Interface Connections

Signal	Pin Number
TX Data +	9
TX Data -	1
RX Data +	11
RX Data -	3
Chassis	7

Table 7. E1 75 Ohm Interface Connections

Signal	Connector
TX	J1
RX	J2

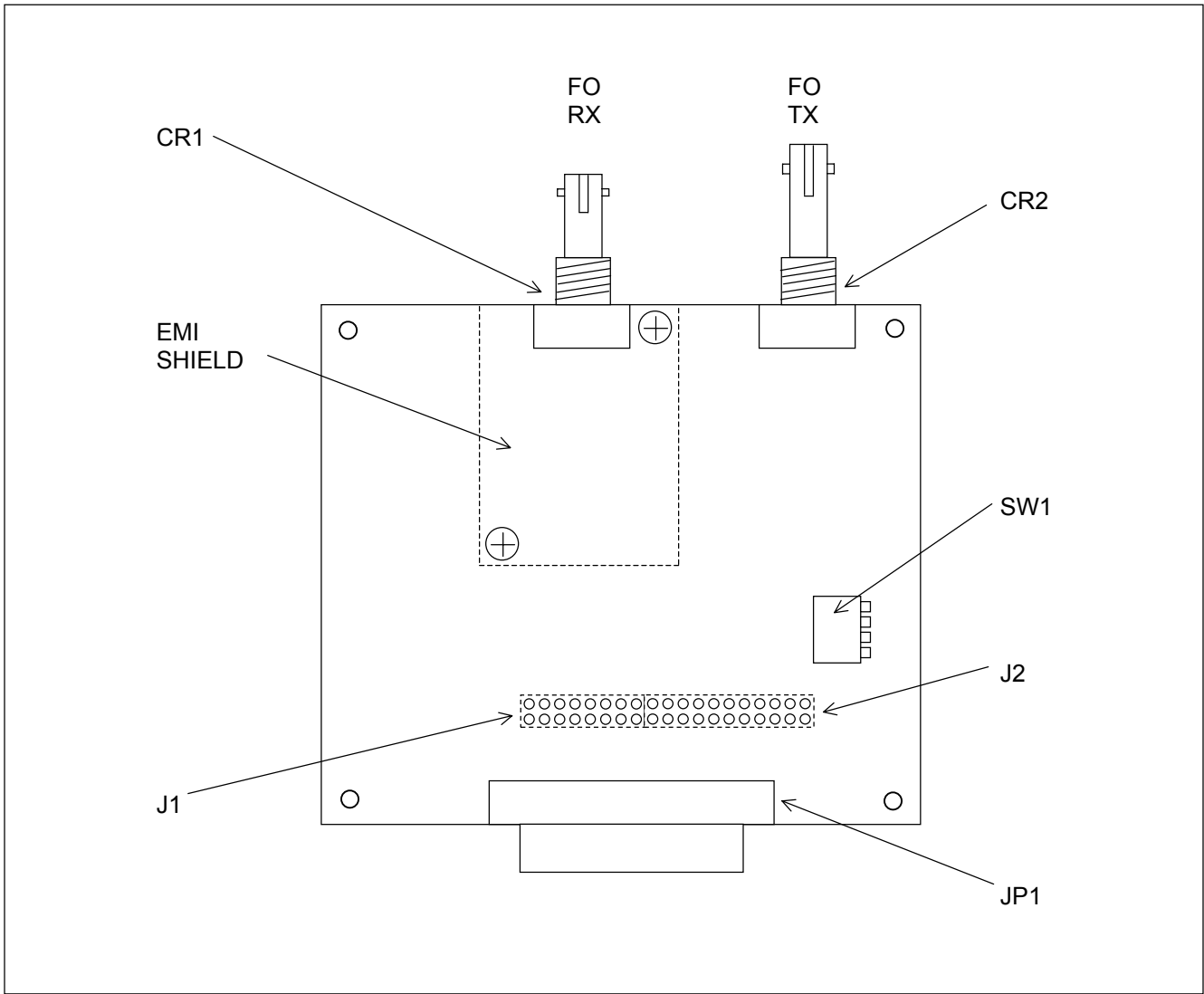

Figure 4. Controls and indicators, typical optical board (Board B)

Table 8. Controls and indicators, typical optical board (Board B)

Reference Designation	Function
CR1	Fiber optic detector
CR2	Fiber optic emitter
J1	Connects signals to board A
J2	Connects signals to board A
JP1	Not used in this application
SW1	Not used in this application

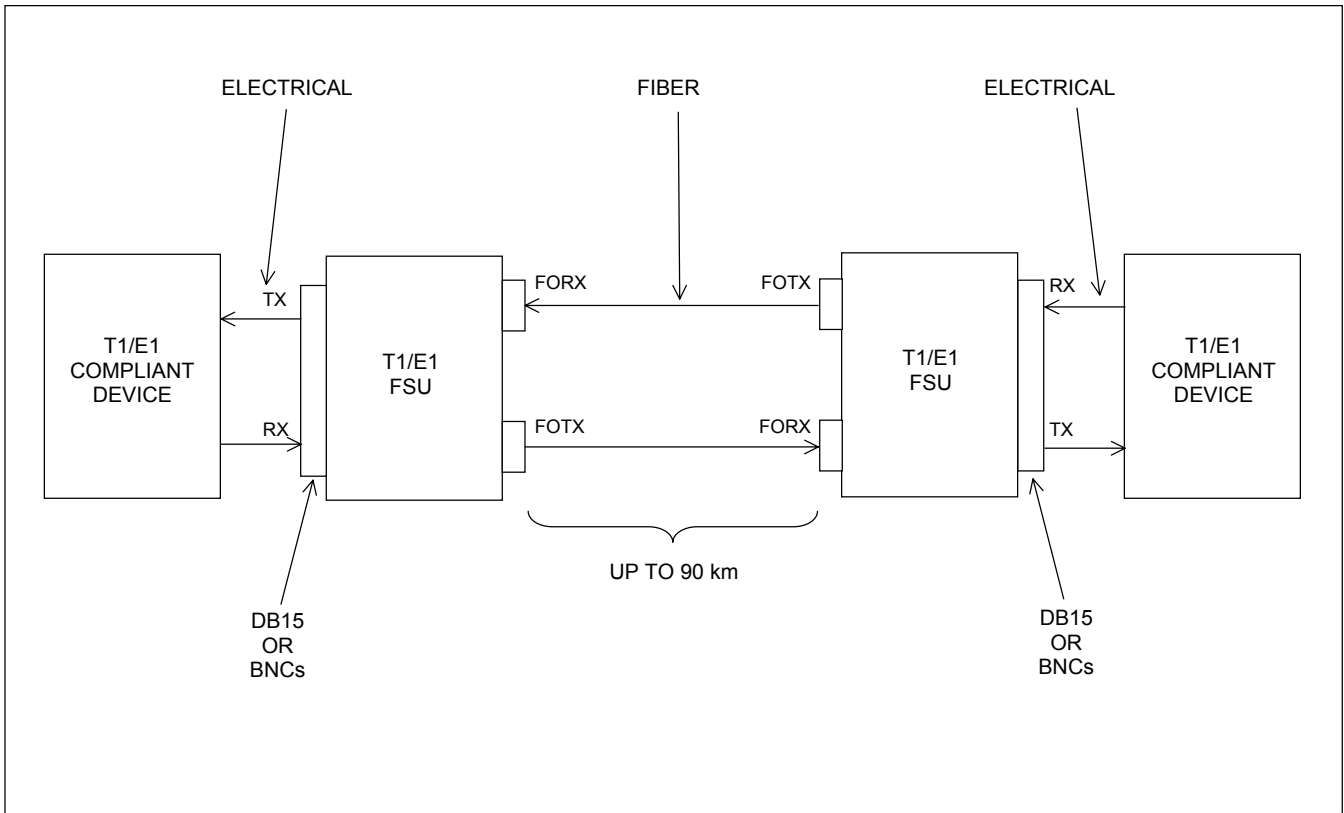

Figure 5. Two T1/E1 FSUs connected End-to-End

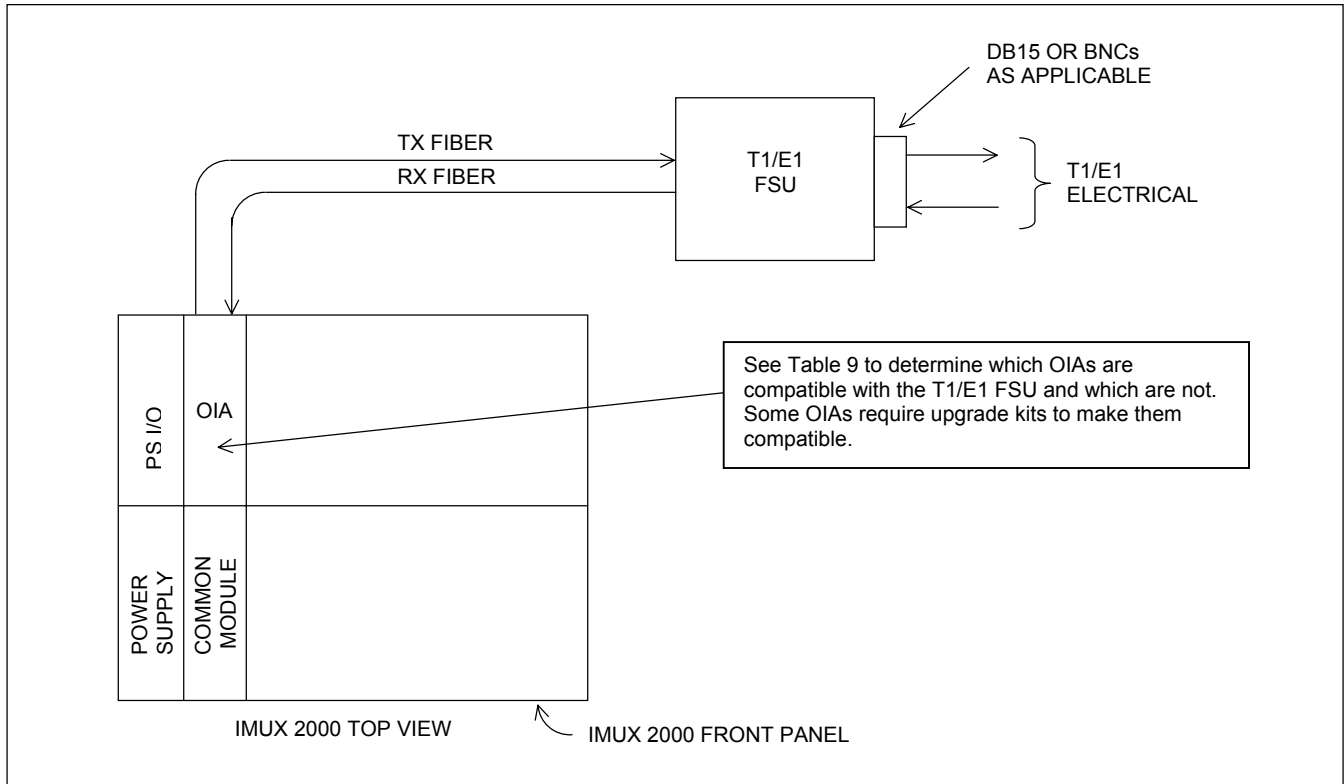

Figure 6. Connecting T1/E1 FSU to IMUX 2000 Chassis

Table 9. T1/E1 FSU And OIA Compatibility Information

OIA Part Number	Application	Comments	Upgrade kit Part Number
107455-201	CM4	CMI encoding is compatible with T1/E1 FSU	
107455-301	CM4	CMI encoding is compatible with T1/E1 FSU	
107455-401	CM4	CMI encoding is compatible with T1/E1 FSU	
107455-501	CM4	CMI encoding is compatible with T1/E1 FSU	
107455-601	CM4	Cannot be used with T1/E1 FSU	
107455-200	8-Port DACS	CMI encoding is compatible with T1/E1 FSU	
107455-300	8-Port DACS	CMI encoding is compatible with T1/E1 FSU	
107455-400	8-Port DACS	CMI encoding is compatible with T1/E1 FSU	
107455-500	8-Port DACS	CMI encoding is compatible with T1/E1 FSU	
9547-1001	CM3 or CM3R	Cannot be used with T1/E1 FSU	
9547-2001	CM3 or CM3R	CMI encoding is compatible with T1/E1 FSU	
9547-3001	CM3 or CM3R	CMI encoding is compatible with T1/E1 FSU	
9547-4001	CM3 or CM3R	CMI encoding is compatible with T1/E1 FSU	
9547-5001	CM3 or CM3R	CMI encoding is compatible with T1/E1 FSU	
9547-1011	CM3R	Cannot be used with T1/E1 FSU	
9547-2011	CM3R	CMI encoding is compatible with T1/E1 FSU	
9547-3011	CM3R	CMI encoding is compatible with T1/E1 FSU	
9547-4011	CM3R	CMI encoding is compatible with T1/E1 FSU	
9547-5011	CM3R	CMI encoding is compatible with T1/E1 FSU	
9547-100	CM3	Cannot be used with T1/E1 FSU	
9547-200	CM3	Requires CMI encoding upgrade kit	107645-200
9547-300	CM3	Requires CMI encoding upgrade kit	107645-300
9547-400	CM3	Requires CMI encoding upgrade kit	107645-400
9547-500	CM3	Requires CMI encoding upgrade kit	107645-500
9547-500-10	CM3	Cannot be used with T1/E1 FSU	
9547-101	CM3R	Cannot be used with T1/E1 FSU	
9547-201	CM3R	Requires CMI encoding upgrade kit	107645-201
9547-301	CM3R	Requires CMI encoding upgrade kit	107645-301
9547-401	CM3R	Requires CMI encoding upgrade kit	107645-401
9547-501	CM3R	Requires CMI encoding upgrade kit	107645-501
9547-150	CM6	Cannot be used with T1/E1 FSU	
9547-250	CM6	Cannot be used with T1/E1 FSU	
9547-350	CM6	Cannot be used with T1/E1 FSU	
9547-351	CM6	Cannot be used with T1/E1 FSU	
9547-450	CM6	Cannot be used with T1/E1 FSU	
9547-550	CM6	Cannot be used with T1/E1 FSU	

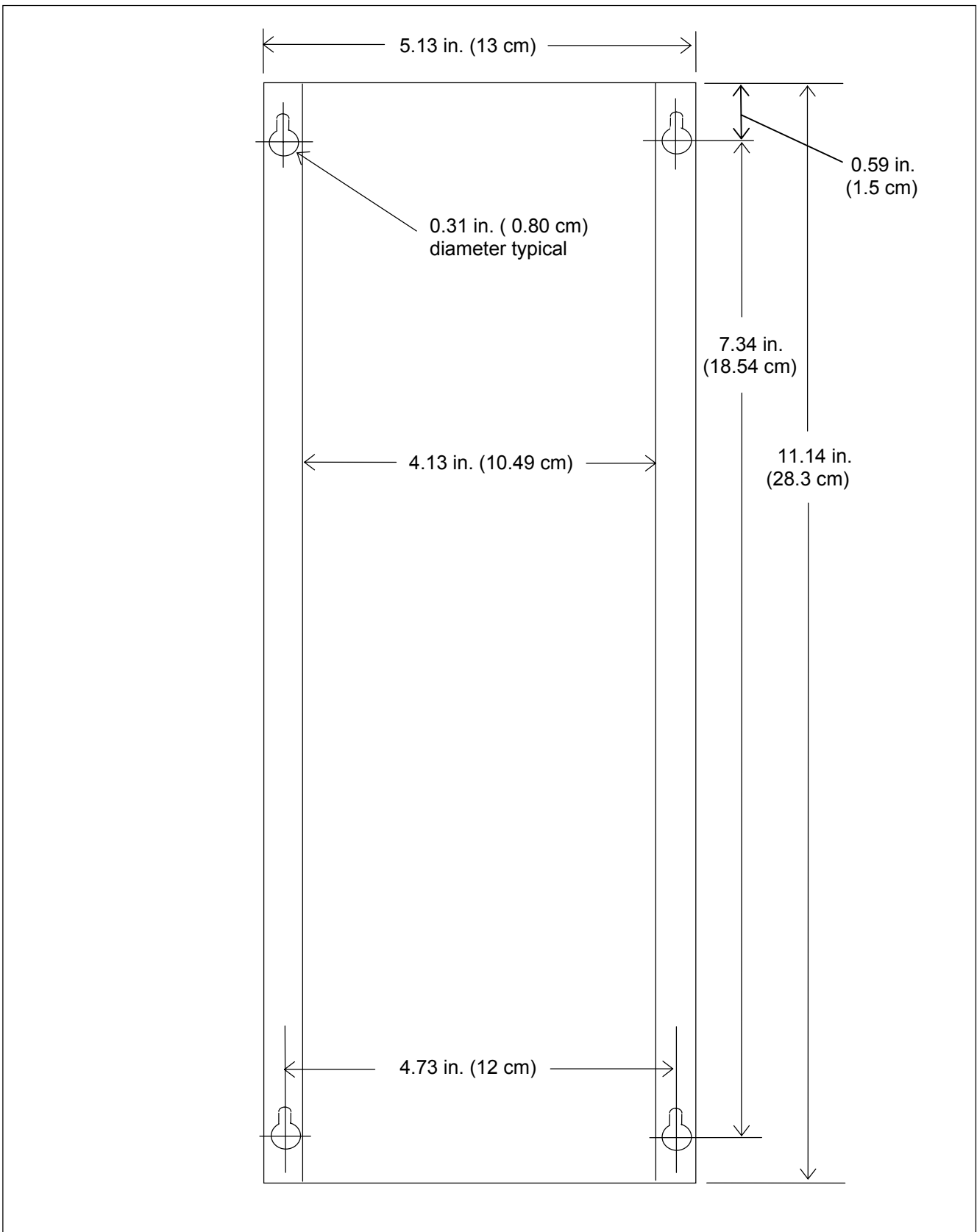

Figure 7. Mounting Dimensions, T1/E1 Fiber Service Unit

NOTICE

The information in this publication is proprietary and confidential to RFL Electronics Inc. No part of this publication may be reproduced or transmitted, in any form or by any means (electronic, mechanical, photocopy, recording, or otherwise), or stored in any retrieval system of any nature, unless written permission is given by RFL Electronics Inc.

This publication has been compiled and checked for accuracy. The information in this publication does not constitute a warranty of performance. RFL Electronics Inc. reserves the right to revise this publication and make changes to its contents from time to time. We assume no liability for losses incurred as a result of out-of-date or incorrect information contained in this publication.

Publication No. ID T1/E1 FSU
Printed in U.S.A.
Revised March 12, 2004

RFL Electronics Inc.
353 Powerville Road
Boonton Township, NJ 07005-9151
Phone: (973) 334-3100
Fax: (973) 334-3863