



RFL Electronics Inc.

INSTRUCTION DATA

RFL (C37.94) Fiber Service Unit

107460-1	RS-449
107460-2	V.35
107460-3	G.703
107460-4	X.21
107460-5	E1

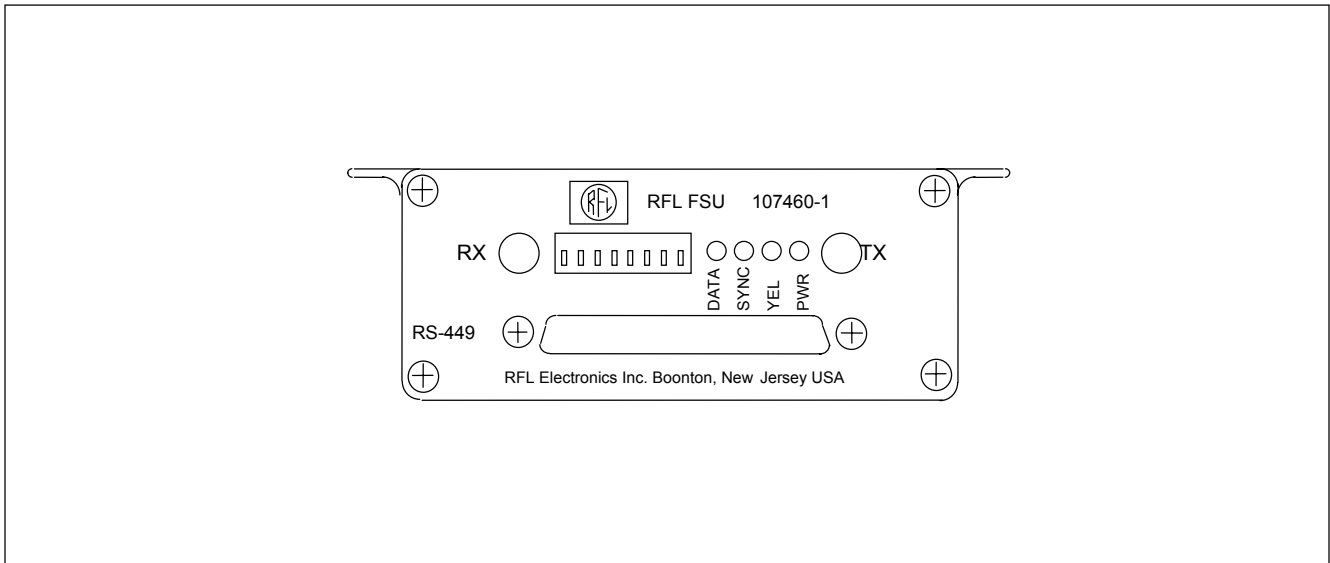

Figure 1. Typical RFL Fiber Service Unit, Front Panel view

DESCRIPTION

The RFL Fiber Service Unit (FSU) provides an interface between synchronous electrical signals and multimode optical fiber. It can be used with the RFL 9300, RFL 9745, RFL IMUX 2000 or other types of multiplexers. It can also be used with any other C37.94 compliant, end device. There are a total of five varieties of FSUs. They use RS-449, V.35, G.703, X.21 and E1 as inputs and outputs on the non-fiber side of the connection. The FSU is a stand-alone device, which is essentially a translator to and from data sent using these five interface standards in accordance with the IEEE C37.94 fiber protocol. The G.703 is 64,000 bps only and thus it has N fixed at 1. The other four versions use a DIP switch to set the value of N. The characteristics of each of the five types of Fiber Service Units, is shown in Tables 1 and 2. Mounting dimensions are shown in Figure 10.

Table 1. Fiber Service Unit General Information

Assembly Number	Interface Type	Interface Cable Connector	Pinouts
107460-1	RS-449	37-pin female	See Table 6
107460-2	V.35	37-pin female	See Table 6
107460-3	G.703	15-pin female	See Table 7
107460-4	X.21	15-pin female	See Table 7
107460-5	E1	15-pin female or two BNCs	See Tables 8 & 9

Table 2. Fiber Service Unit Characteristics

Assembly Number	Type	Wavelength/ Mode	Connector Type	Receiver Sensitivity	Tx Level	Typical Distance
107460-1	LED Emitter/ Detector	830 (+/- 40 nm) multimode	ST	-11dBm to -32dBm	-14dBm to -21dBm	Up to 2km (1.2 mi.)
107460-2					Average into 50um fiber	
107460-3					-11dBm to -18dBm	
107460-4					Average into 62.5um fiber	
107460-5						

SPECIFICATIONS

As of the date this Instruction Data Sheet was published, the following specifications apply to the RFL Fiber Service Unit. Because all RFL products undergo constant refinement and improvement, these specifications are subject to change without notice.

IEEE Standard: C37.94 for N times 64 kilobit per second optical fiber interfaces between teleprotection and multiplexer equipment.

Signal Connector Type:

- 15-pin male type D subminiature for G.703 and X.21
- 37-pin male type D subminiature for RS-449 and V.35
- 15-pin male type D subminiature or dual BNCs for E1

Data Rate: Programmable from 64 kb/s to 768 kb/s in accordance with Table 5.

Input Power Requirements:

38 to 150 Vdc @ 3Watts

Operating Temperature:

-30°C to +60°C (-22°F to +140°F)

Relative Humidity: 95 percent @ 40°C, non-condensing.

Dimensions:

- Width: 5.13 inches (13 cm)
- Height: 1.77 inches (4.5 cm)
- Depth: 8.51 inches (21.6 cm)

Mounting Dimensions: In accordance with Figure 10.

INSTALLATION

Installation involves mounting the FSU module in its desired location, connecting all signal, coaxial and power cables, and programming the module data rate and other configuration settings.

To install the module, proceed as follows:

1. Carefully inspect the module for any signs of shipping damage. If you suspect damage to the module, immediately call RFL Customer Service at the number given at the bottom of this page.
2. Check the assembly number on the front panel of the module to make sure the unit is compatible with your interface requirement as shown in Table 1.
3. Use Table 6 as a wiring guide for the D subminiature connector if your interface is RS-449 or V.35. Use Table 7 as a wiring guide for the D subminiature connector if your interface is X.21 or G.703. Use Table 8 as a wiring guide for the D subminiature connector if your interface is 120 ohm E1. Use Table 9 as a wiring guide for the BNC connectors if your interface is 75 ohm E1. When fastening the D subminiature connector, make sure that the screws on both ends of the mating connector are tightened to secure the connector to the FSU front panel.

NOTE

ALL CABLING TO AND FROM THE FIBER SERVICE UNIT INTERFACE CONNECTOR MUST UTILIZE SHIELDED TWISTED PAIR OR COAXIAL CABLE TO MINIMIZE CROSSTALK AND INTERFERENCE FROM EXTERNAL SOURCES.

CAUTION

BEFORE ATTEMPTING TO MAKE POWER CONNECTIONS TO THE FIBER SERVICE UNIT, MAKE SURE THAT YOUR POWER SOURCE IS COMPATIBLE WITH THE FSU. IF THE IMPROPER VOLTAGE IS CONNECTED TO THE FSU, COMPONENT DAMAGE MAY RESULT.

4. Connect input power to the following terminals on the rear-panel terminal block connector TB1, as follows:
 - Station battery positive TB1-1
 - Station battery negative TB1-3
 - Ground TB1-5 and TB1-6
5. Fiber optic cables with type ST series bayonet fiber optic connectors must be connected to the fiber optic heads on the front panel of the FSU module and to the far end chassis. When connecting fiber optic cables, make sure the connectors are properly aligned before tightening, and then fully tighten them. This will help minimize losses in the connector.
6. For 107460-1 to -5, select the FSU data rate using DIP switches SW1-1 through SW1-4 in accordance with Table 5. The FSU data rate must be set to the same data rate as the unit at the other end of the fiber. The settings of SW1-1 through SW1-4 are ignored by the (107460-3) G.703 module since its data rate is fixed at 64 kb/s. For an RFL 9745 the data rate is 64 kb/s. For an RFL 9300 the data rate is 64 kb/s.
- 7a. For 107460-1, -2, -4, select a normal or inverted transmit data clock by using DIP switch SW1-5.
 - Place SW1-5 to the DOWN position to select normal transmit data clock.
 - Place SW1-5 to the UP position to select inverted transmit data clock.For 107460-3, set SW1-5 to the UP position.

- 7b. For 107460-5, enable or disable CRC4 generation by using DIP switch SW1-5.
Place SW1-5 to the DOWN position to enable CRC4.
Place SW1-5 to the UP position to disable CRC4.
- 8a. For 107460-1, -2 and -4, select a normal or inverted receive data clock by using DIP switch SW1-6.
Place SW1-6 to the DOWN position to select normal receive data clock.
Place SW1-6 to the UP position to select inverted receive data clock.
For 107460-3, set SW1-6 to the DOWN position.
- 8b. For 107460-5, select AMI or HDB3 encoding by using DIP switch SW1-6.
Place SW1-6 to the DOWN position to select HDB3 encoding.
Place SW1-6 to the UP position to select AMI encoding.
- 9a. For 107460-1, -2 & -4, select a normal or inverted data by using DIP switch SW1-7.
This switch is ignored by 107460-3.
Place SW1-7 to the DOWN position to select inverted data.
Place SW1-7 to the UP position to select normal data.
- 9b. For 107460-5, enable or disable Fiber Loopback by using DIP switch SW1-7.
Place SW1-7 to the DOWN position to enable Fiber Loopback.
Place SW1-7 to the UP position to disable Fiber Loopback.
- 10a. For 107460-3, enable or disable octet timing on the G.703 module by using DIP switch SW1-8. This switch is ignored by 107460-1, -2 and -4.
Place SW1-8 to the UP position to enable octet timing.
Place SW1-8 to the DOWN position to disable octet timing.
- 10b. For 107460-5, enable or disable E1 Loopback by using DIP switch SW1-8.
Place SW1-8 to the UP position to enable octet timing.
Place SW1-8 to the DOWN position to disable octet timing.
11. For 107460-5, set switches and jumpers on Board B in accordance with Table 4.
12. The FSU is now installed and is ready to be placed in service. For more information consult the Instruction Manual for the RFL 9745, RFL 9300 or the RFL IMUX 2000 as applicable.

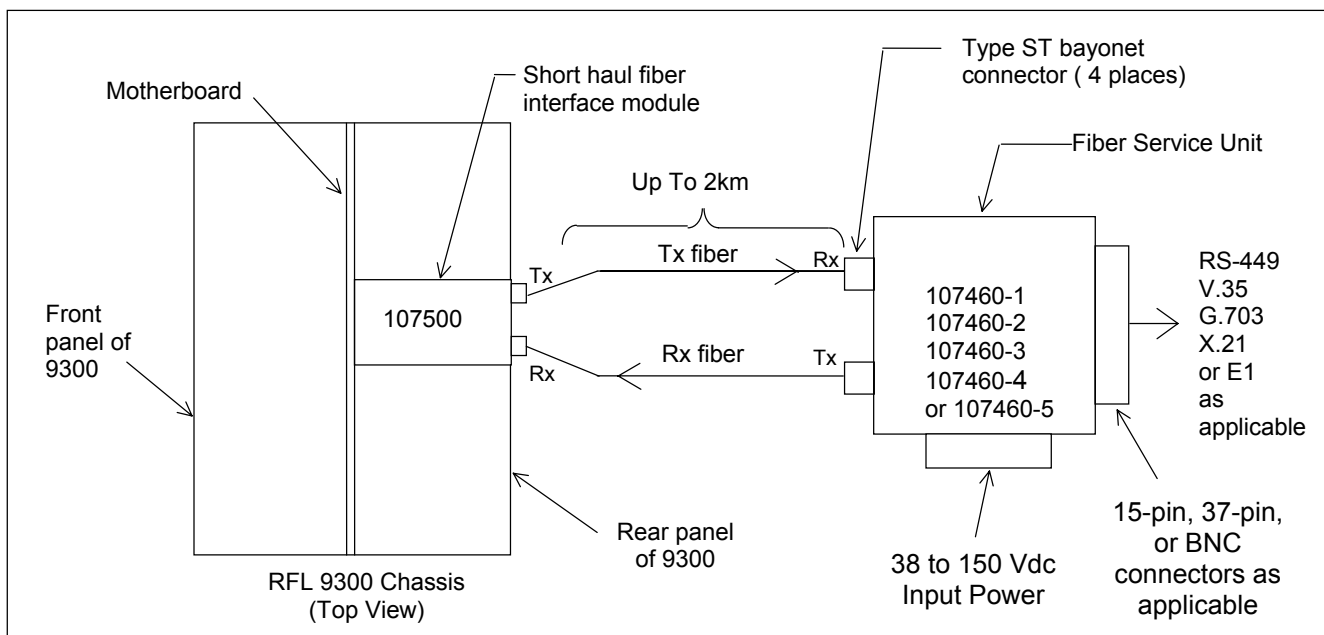

Figure 2. Connecting the FSU to an RFL 9300

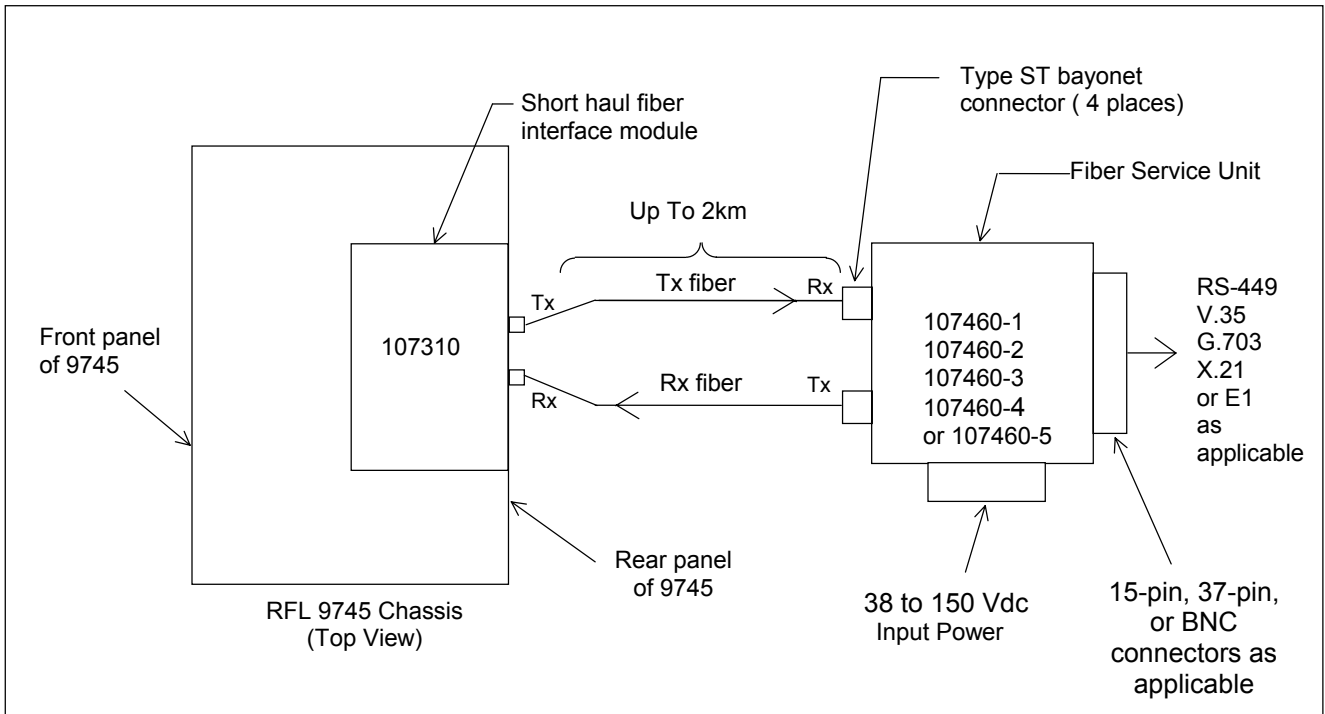

Figure 3. Connecting the FSU to an RFL 9745

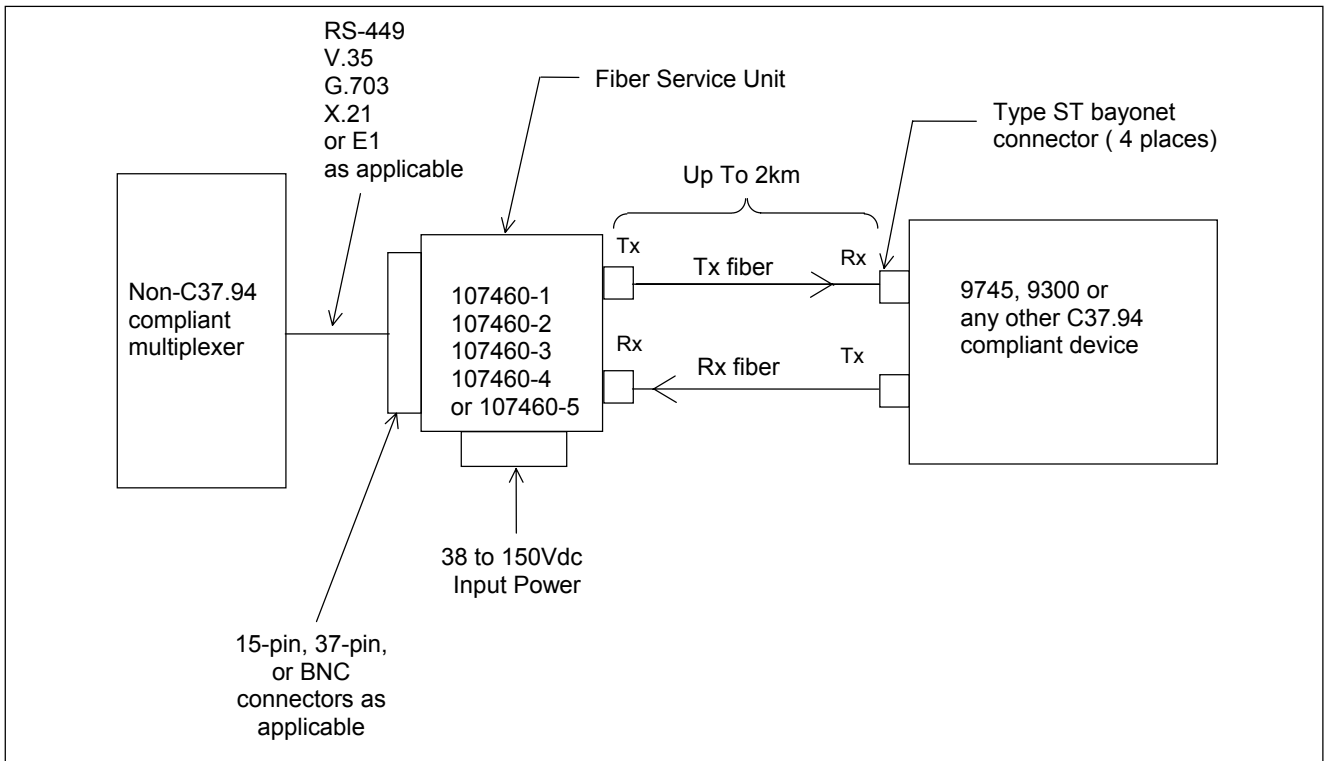

Figure 4. Connecting the FSU to a non-C37.94 compliant multiplexer

CONTROLS AND INDICATORS (107460-1 to 107460-4)

The RFL FSU (107460-1 to 107460-4) has user controls and indicators as shown in Figures 5 and 6. Figure 5 shows the location of all controls, indicators and connectors on the front and rear panels of the FSU module. Figure 6 shows the location of controls and indicators on ECB number 107464. The function of all controls and indicators are described in Table 3.

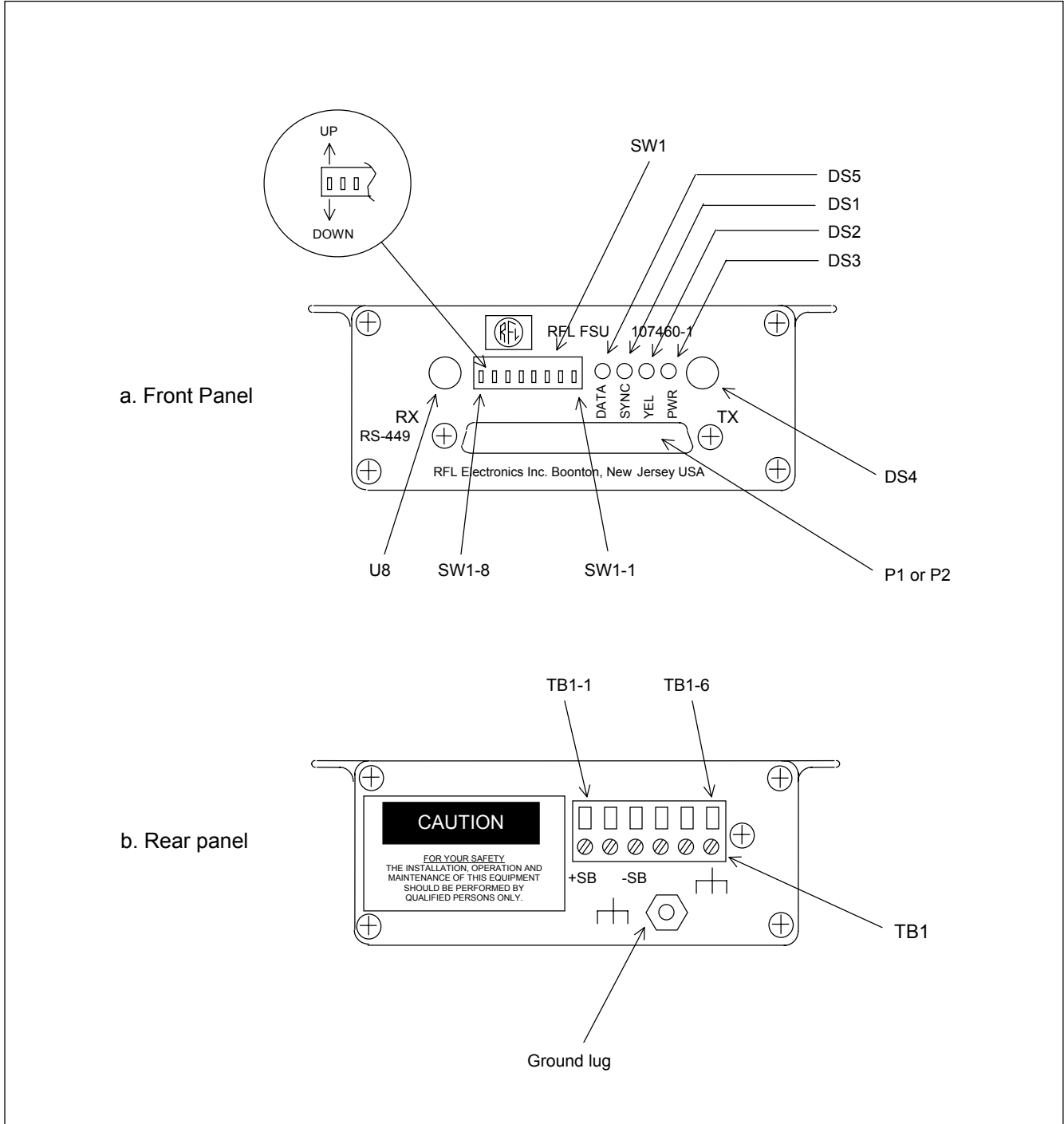

Figure 5. Fiber Service Unit, front and rear panel controls and indicators (107460-1 to 107460-4)

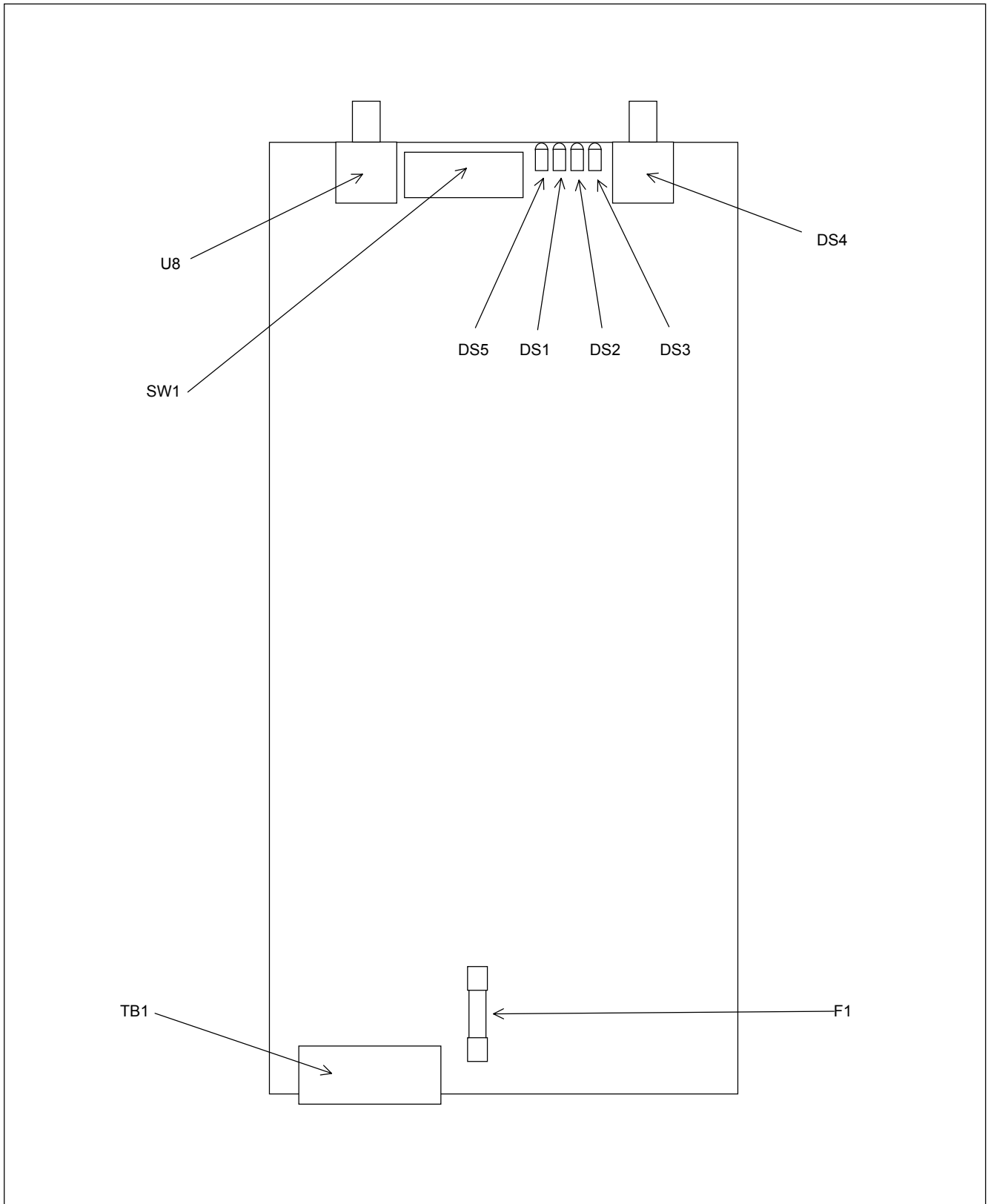

Figure 6. Fiber Service Unit ECB No. 107463 (Board A), controls and indicators (107460-1 to 107460-4)

Table 3. Controls and indicators, Fiber Service Unit (107460-1 to 107460-4)

Location	Reference Designation	Function
Front Panel	U8	Fiber optic detector
	SW1	8-position DIP switch used to set FSU operating parameters as follows: SW1-1 through SW1-4: Selects Data Rate in accordance with Table 5. SW1-5: For 107460-1, -2 and -4, Selects NORMAL or INVERTED Xmit Data Clock as follows: Down = Normal Clock Up = Inverted Clock For 107460-3, SW1-5 must be UP SW1-6: For 107460-1, -2 and -4 selects NORMAL or INVERTED Receive Data Clock as follows: Down = Normal Clock Up = Inverted Clock For 107460-3, SW1-6 must be DOWN SW1-7: On 107460-1, -2 and -4 selects normal or inverted data as follows Down = Inverted Data Up = Normal Data SW1-8: (This switch applies to G.703 only and is ignored by all other FSU modules) Selects octet timing as follows: Up = Octet Timing Enabled Down = Octet Timing Disabled
	DS4	Fiber optic emitter
	DS5	DATA LED (green), illuminated when data is present on the electrical interface.
	DS1	SYNC LED (green), illuminated when the optical signal is in sync.
	DS2	YEL LED (yellow), Yellow Alarm Indication, illuminated when the remote fiber receiver has failed and the remote transmitter is sending a yellow code by the local fiber receive channel.
	DS3	PWR LED (green), illuminated when power is ON.
	P1 or P2	Connector
Rear Panel	TB1	Power connector
	Ground Lug	Ground lug
On ECB No. 107463 Board A	F1	FSU power supply fuse (see note below)

Note: F1 is a 0.25 Amp, 250 Volt SLO-BLO, 5x20 mm fuse.
 Littlefuse part number is: 239.250
 BUS part number is: GMD-.25A

CONTROLS AND INDICATORS (107460-5)

The RFL FSU (107460-5) has user controls and indicators as shown in Figures 7, 8 and 9. Figure 7 shows the location of all controls, indicators and connectors on the front and rear panels of the FSU module. Figures 8 and 9 show the location of controls and indicators on Board A and Board B. The function of all controls and indicators are described in Table 4.

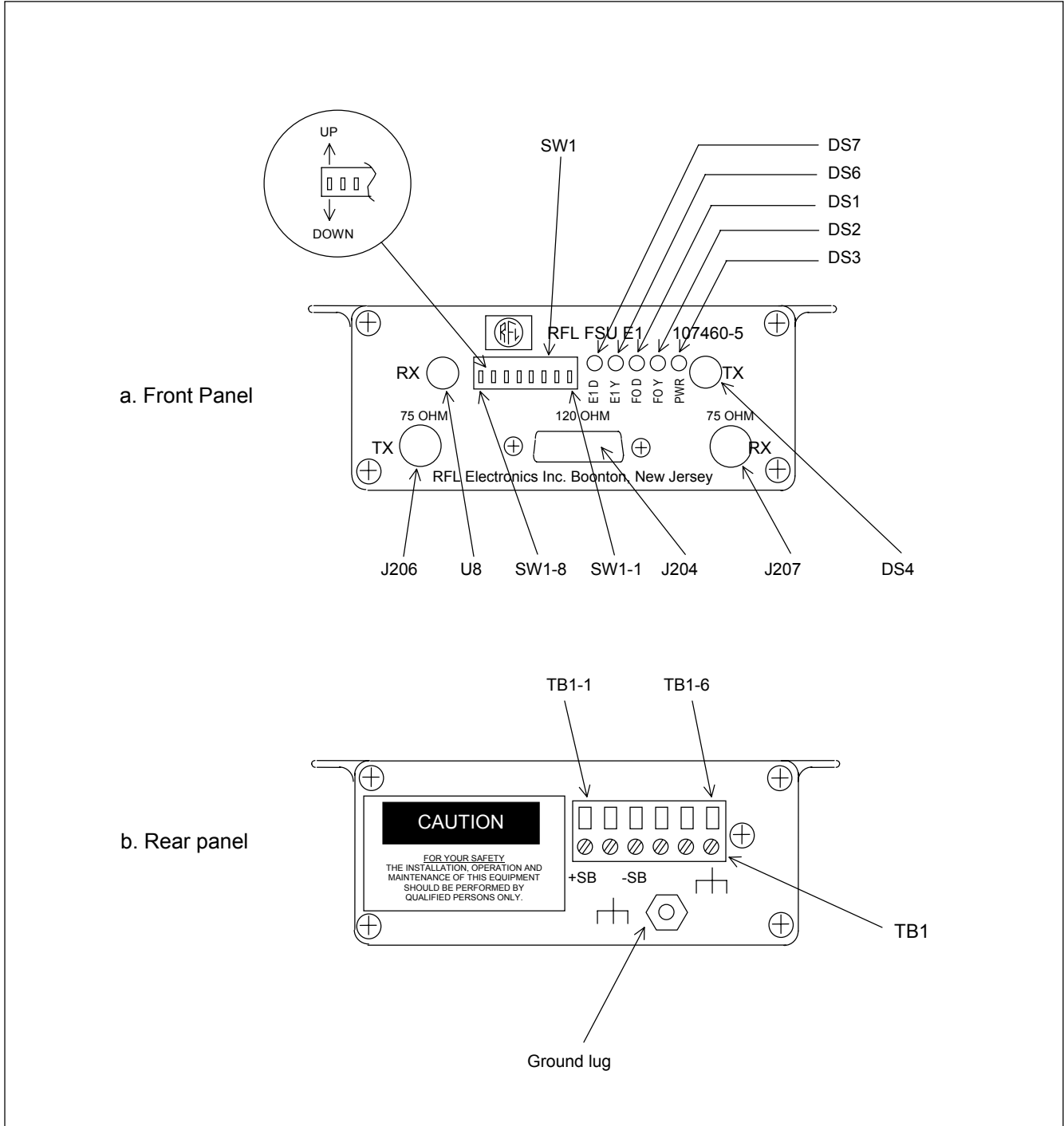

Figure 7. Fiber Service Unit, front and rear panel controls and indicators (107460-5)

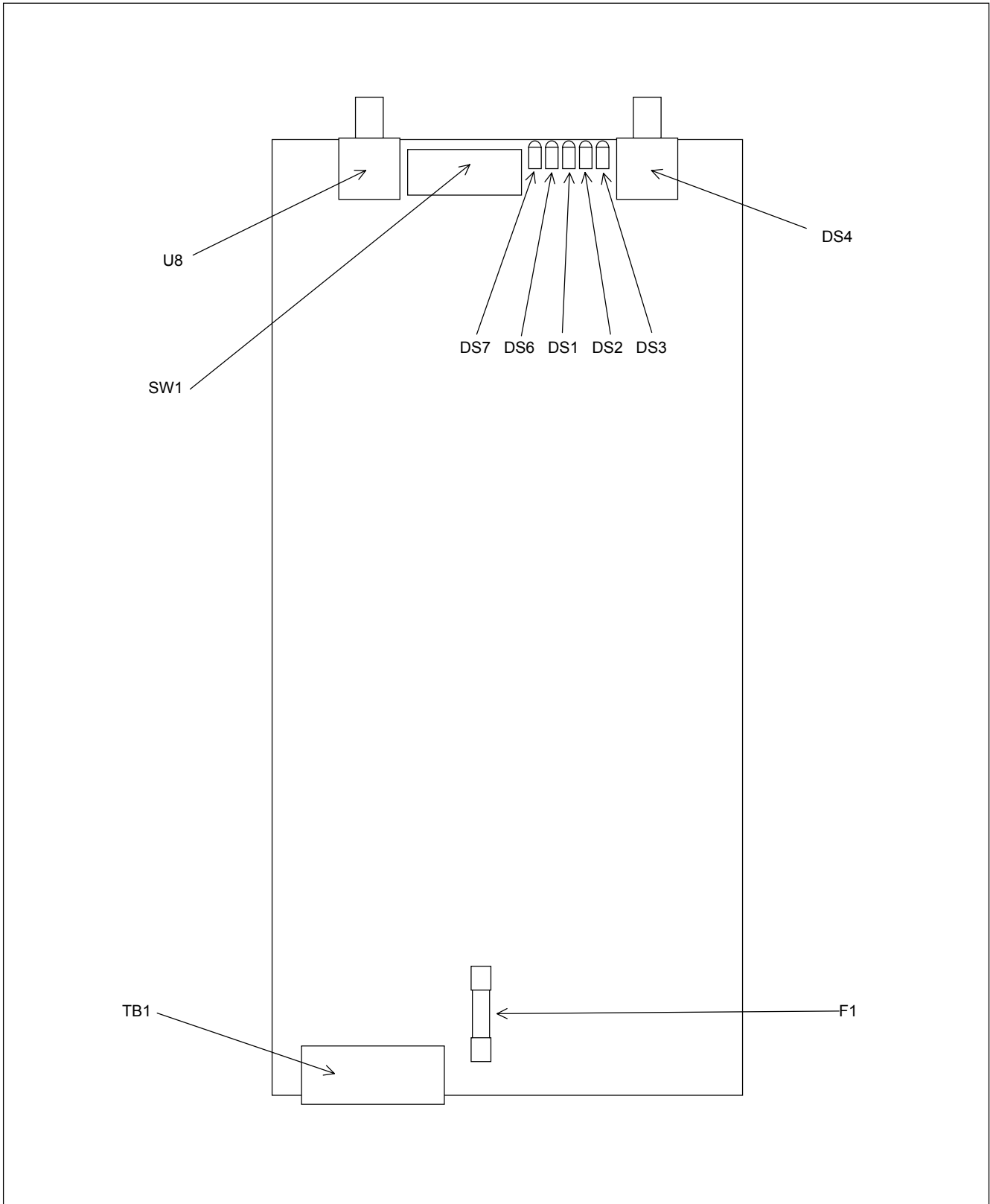

Figure 8. Fiber Service Unit ECB No. 107463-5 (Board A), controls and indicators (107460-5)

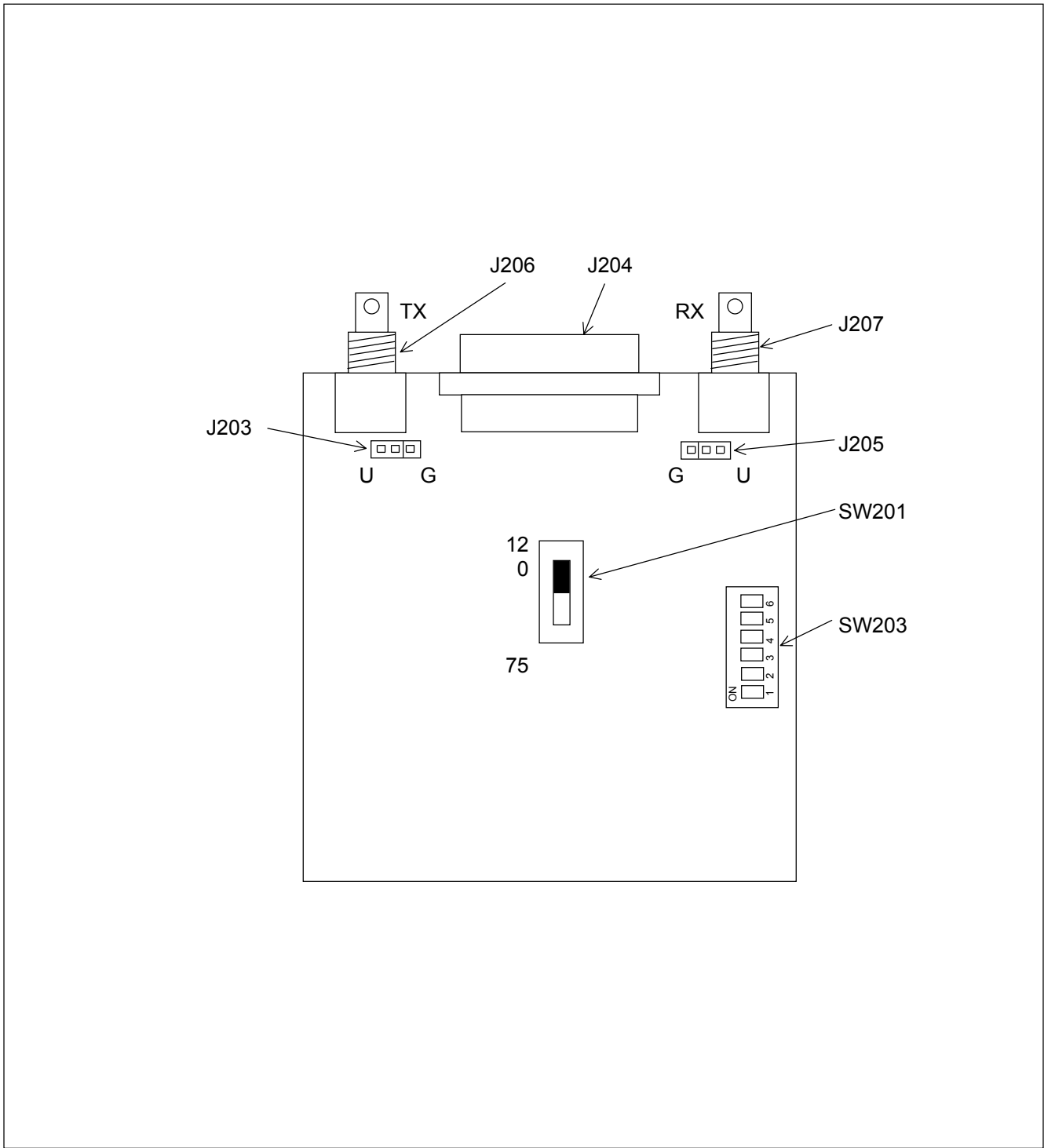

Figure 9. Fiber Service Unit ECB No. 107463-5 Board B

Table 4. Controls and indicators, Fiber Service Unit (107460-5)

Location	Reference Designation	Function
Front Panel	U8	Fiber optic detector
	SW1	8-position DIP switch used to set FSU operating parameters as follows: SW1-1 through SW1-4: Selects Data Rate in accordance with Table 5. SW1-5: Selects CRC generation as follows: Down = Generate CRC4 Up = Do not generate CRC4 SW1-6: Selects AMI or HDB3 encoding as follows: Down = Selects HDB3 encoding Up = Selects AMI encoding SW1-7: Enables or disables fiber Loopback as follows: Up = Loopback enabled Down = Loopback disabled SW1-8: Enables or disables E1 Loopback as follows: Up = Loopback Enabled Down = Loopback Disabled
	DS1	FO D LED (green) Lights green when fiber optic data is being received.
	DS2	FO Y LED (yellow) Lights yellow when remote fiber unit is not receiving data.
	DS3	PWR LED (green) Lights green when power is applied to input terminals.
	DS4	Fiber Optic Emitter
	DS6	E1 Y LED (yellow) Lights yellow when the remote E1 unit is not receiving data.
	DS7	E1 D LED (green) Lights green when E1 data is being received.
	J204	DB-15 120 ohm E1 Connector
	J206	75 ohm E1 TX Connector
J207	75 ohm E1 RX Connector	
Rear Panel	TB1	Input power connector (Connect +dc supply to +SB, connect -dc supply to -SB)
	Ground Lug	Ground lug (Connect to earth ground)
On ECB No. 107463-5 Board A	F1	FSU power supply fuse (see note below)

Note: F1 is a 0.25 Amp, 250 Volt SLO-BLO, 5x20 mm fuse.
 Littlefuse part number is: 239.250
 BUS part number is: GMD-.25A

Table 4. continued - Controls and indicators, Fiber Service Unit (107460-5)

Location	Reference Designation	Function
On ECB No. 107463-5 Board B	J203, J205	Used to ground the outer conductor of the BNC connectors when necessary. Both jumpers should be set to "U" when using the DB-15 E1 port. J203 is set to "G" and J205 is set to "U" when using the BNC E1 ports
	J204	120 ohm E1 port (DB-15 male connector) Refer to Table 8 for interface connections
	J206	75 ohm E1 TX port (BNC connector)
	J207	75 ohm E1 RX port (BNC connector)
	SW201	Selects impedance of E1 port as follows: Set to 75 when using 75-ohm BNC ports Set to 120 when using 120-ohm DB-15 port
	SW203	Used to set E1 operating parameters as follows: SW203-1 Selects Timing Mode ON = Thru timing OFF = Internal timing SW203-2 For factory use only (Switch must be set to ON position) SW203-3 Selects Normal operation or Transmit all ones, on E1 port. ON = Normal operation (default setting) OFF = Transmit all ones SW203-4 Enables or disables jitter attenuator ON = Disable jitter attenuator OFF = Enable jitter attenuator (default setting) SW203-5 Jitter attenuator selection ON = Receiver (default setting) OFF = Transmitter SW203-6 Selects inverted data ON = Inverted data OFF = Normal operation (default setting)

Table 5. Data Rate Selection

Data Rate (KB/s)	N	SW1-1	SW1-2	SW1-3	SW1-4
64	1	Down	Down	Down	Down
128	2	Down	Down	Up	Up
192	3	Down	Down	Up	Down
256	4	Down	Up	Down	Up
320	5	Down	Up	Down	Down
384	6	Down	Up	Up	Up
448	7	Down	Up	Up	Down
512	8	Up	Down	Down	Up
576	9	Up	Down	Down	Down
640	10	Up	Down	Up	Up
704	11	Up	Down	Up	Down
768	12	Up	Up	Down	Up

Note 1. G.703 is 64 kb/s only and has N fixed at 1.

Note 2. Down = OPEN, Up = CLOSED.

Table 6. RS-449 and V.35 Interface Connections

RS-449 and V.35	
Signal	Pin Number
RD(A)	6
RD(B)	24
RT(A)	8
RT(B)	26
ST(A)	5
ST(B)	23
SD(A)	4
SD(B)	22
Ground	1, 19

Table 7. X.21 and G.703 Interface Connections

X.21 and G.703	
Signal	Pin Number
RXD_A	4
RXD_B	11
RT(A5)	6
RT(B5)	13
TXD_A	2
TXD_B	9
Ground	1, 8

Table 8. E1 120 Ohm Interface Connections

Signal	Pin Number
TX Data +	9
TX Data -	1
RX Data +	11
RX Data -	3
Chassis	7

Table 9. E1 75 Ohm Interface Connections

Signal	Connector
TX	J206
RX	J205

a. Fiber Service Unit front view

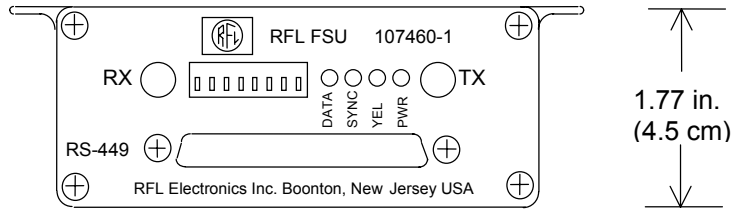

b. Fiber Service Unit top view

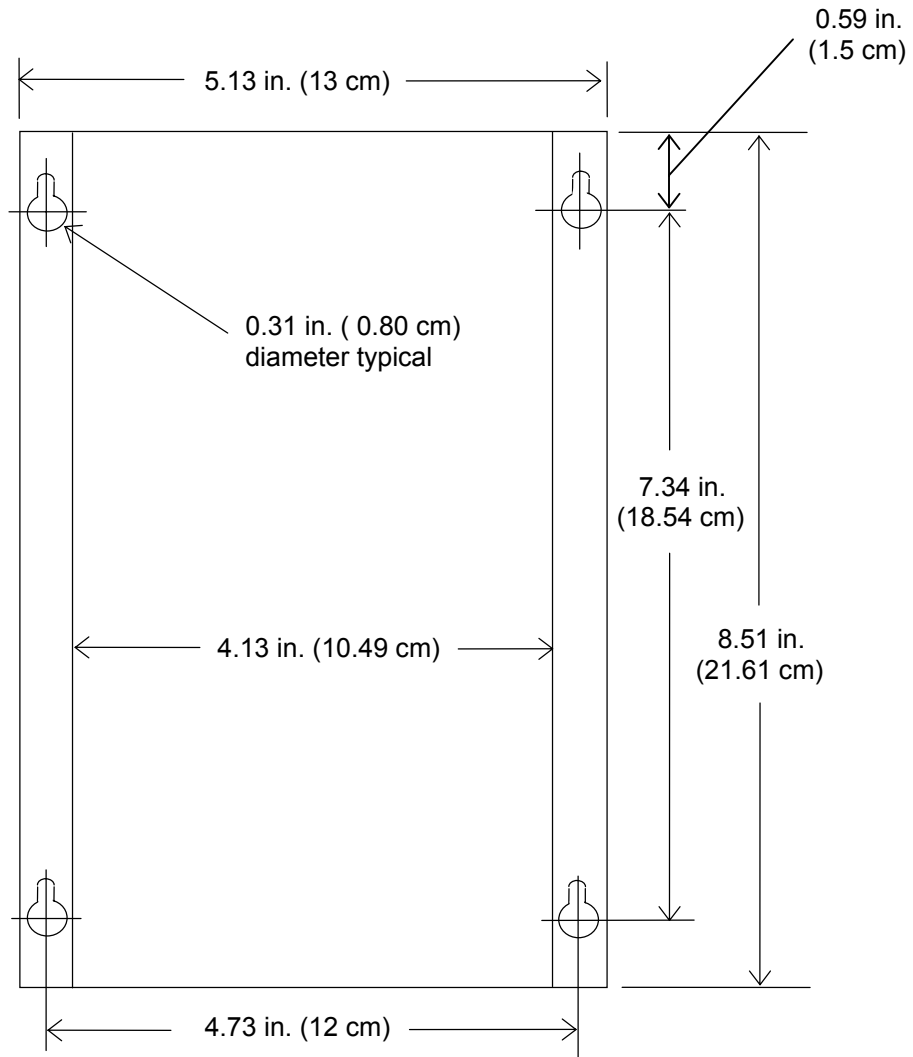

Figure 10. Mounting Dimensions, RFL 93 FSU Fiber Service Unit (107460-1 to 107460-5)

NOTICE

The information in this publication is proprietary and confidential to RFL Electronics Inc. No part of this publication may be reproduced or transmitted, in any form or by any means (electronic, mechanical, photocopy, recording, or otherwise), or stored in any retrieval system of any nature, unless written permission is given by RFL Electronics Inc.

This publication has been compiled and checked for accuracy. The information in this publication does not constitute a warranty of performance. RFL Electronics Inc. reserves the right to revise this publication and make changes to its contents from time to time. We assume no liability for losses incurred as a result of out-of-date or incorrect information contained in this publication.

Publication No. ID C37.94FSU
Printed in U.S.A.
Revised March 14, 2005

RFL Electronics Inc.
353 Powerville Road
Boonton Township, NJ 07005-9151
Phone: (973) 334-3100
Fax: (973) 334-3863